

WALL CABINET ASSEMBLY INSTRUCTION

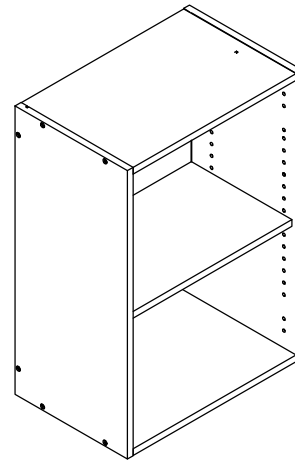

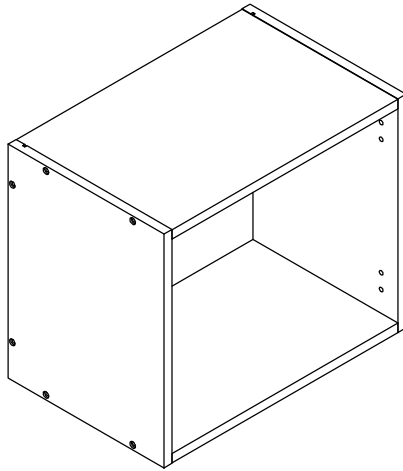
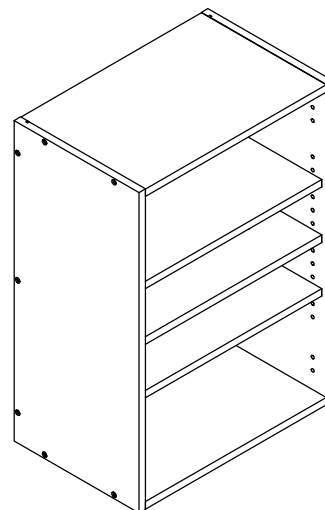
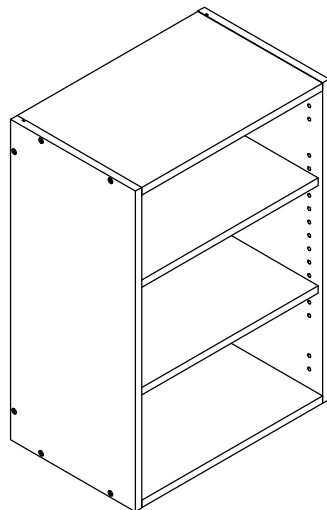

ITEM NO.				
UW2412	UW2415	UW2418	UW121224	UW121824
UW2712	UW2715	UW2718	UW151224	UW151824
UW3012	UW3015	UW3018	UW181224	UW181824
UW3312	UW3315	UW3318	UW241224	UW241824
UW3612	UW3615	UW3618	UW301224	UW301824
			UW331224	UW331824
			UW361224	UW361824
			UW3615 24	UW362024

ITEM NO.	
UW1223	UW122324
UW1523	UW152324
UW1823	UW182324
UW2123	UW242324
UW2423	UW302324
UW2723	UW332324
UW3023	UW362324
UW3323	
UW3623	



ITEM NO.	
UW0930	UW0935
UW1230	UW1235
UW1530	UW1535
UW1830	UW1835
UW2130	UW2135
UW2430	UW2435
UW2730	UW2735
UW3030	UW3035
UW3330	UW3335
UW3630	UW3635

ITEM NO.
UW0940
UW1240
UW1540
UW1840
UW2140
UW2440
UW2740
UW3040
UW3340
UW3640

Hardware		Fitting	
1	Screw	 $\varnothing 7 * 50 \text{mm} (2")$	14/16PC
2	Shelf Support		0/4/8/12PC

A	Left/Right Side Panel	2PC
B	Top/Bottom Panel	2PC
C	Adjustable Shelf	0~3PC
D	Back Panel	1PC
E	Support Rail	2/3PC

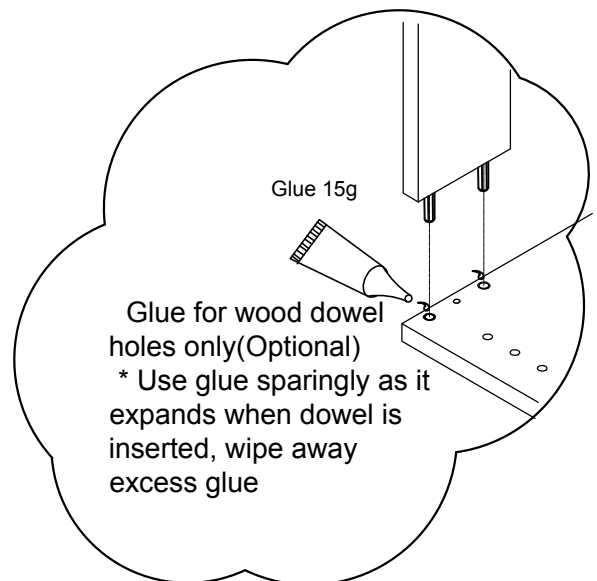
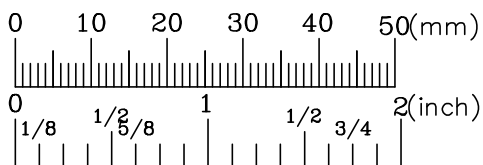

Step1

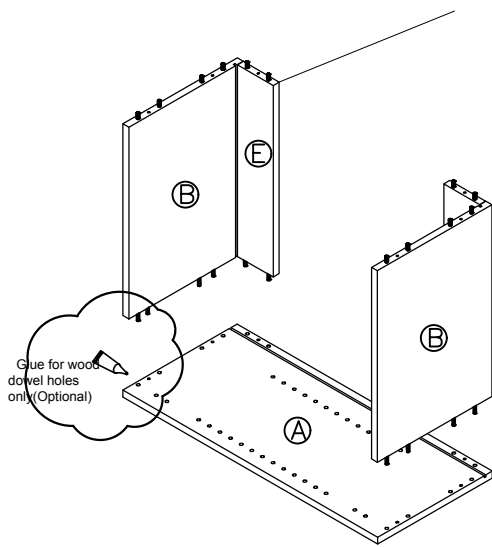

35" and 40" height cabinet, there are three support rails on the back

Step2

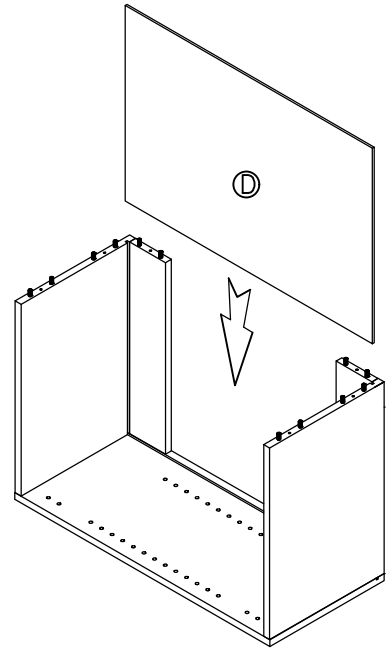

Step3

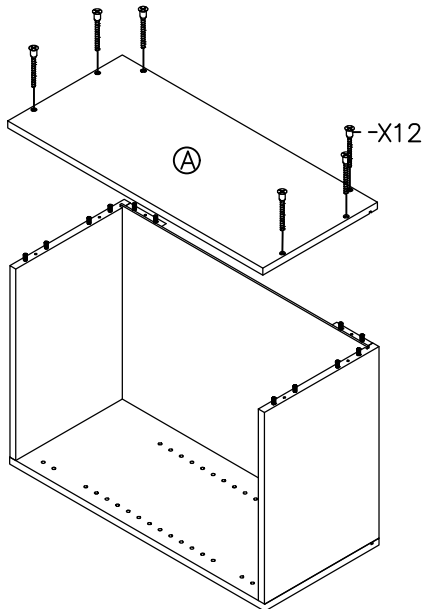

Step4

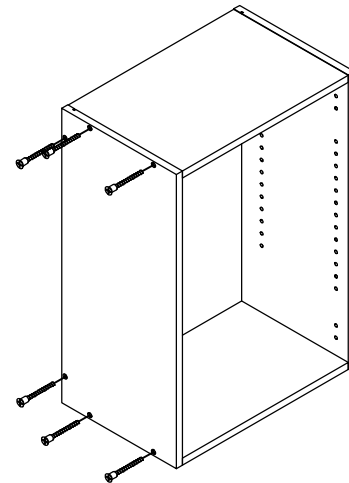

Step5

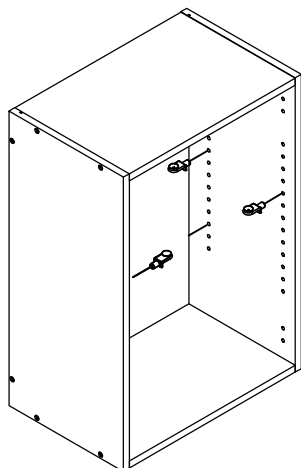

Height	Shelf QTY
12"/15"/18"	0 PC
23"	1 PC
30"/35"	2 PC
40"	3 PC

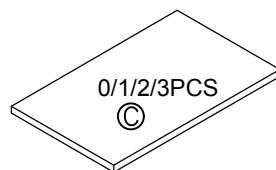

Step6

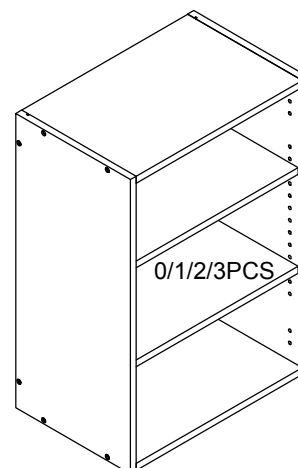

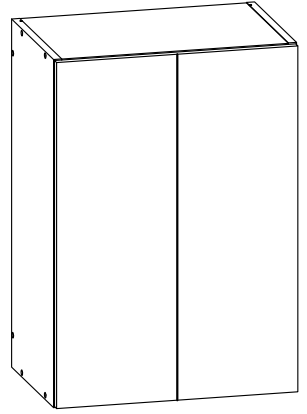
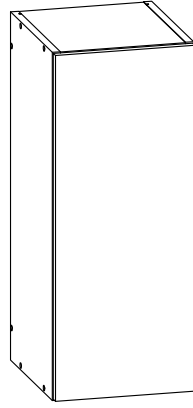
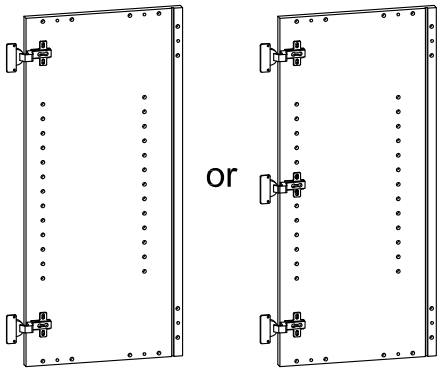

Lift Up Door

Step1

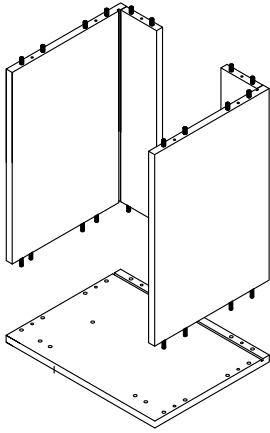

Step2

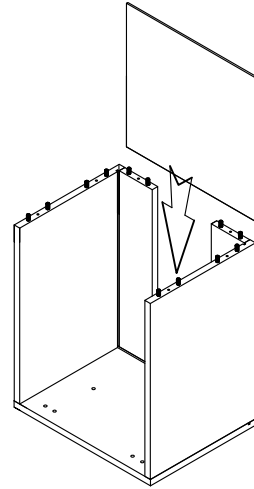

Step3

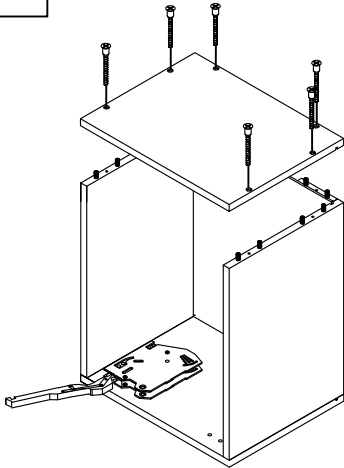

Step4

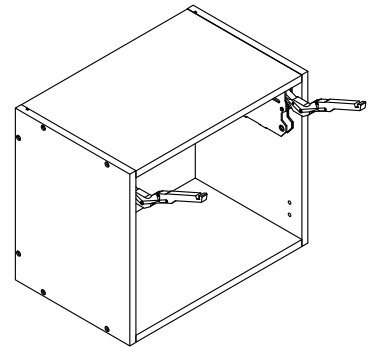

Step5

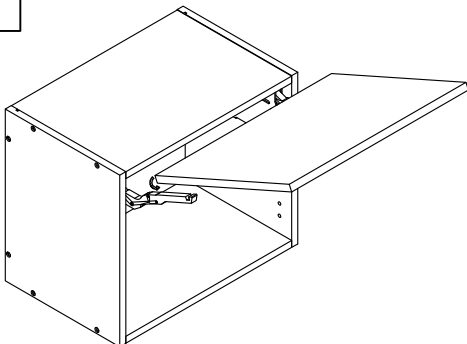

Step6

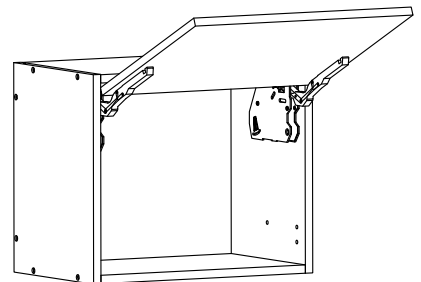

Blind Wall Cabinet

CODE	CAB	DOOR		PANEL		CODE	CAB	DOOR		PANEL	
WBC24 /27 30	UW2430	1	D0930	1	BL1530	WBC24 /27 35	UW2435	1	D0935	1	BL1535
WBC27 /30 30	UW2730	1	D1230	1	BL1530	WBC27 /30 35	UW2435	1	D1235	1	BL1535
WBC30 /33 30	UW3030	1	D1530	1	BL1530	WBC30 /33 35	UW2435	1	D1535	1	BL1535
WBC33 /36 30	UW3330	1	D1830	1	BL1530	WBC33 /36 35	UW2435	1	D1835	1	BL1535
WBC36 /39 30	UW3630	1	D2130	1	BL1530	WBC36 /39 35	UW2435	1	D2135	1	BL1535

Blind Wall Cabinet

1. Fix the hinge on the blind panel first
2. Lay the board on the top of the carcass, keep each side 1.5mm gap
3. Screw the blind panel into the carcass

WBC24 /27 40	UW2440	1	D0940	1	BL1540
WBC27 /30 40	UW2440	1	D1240	1	BL1540
WBC30 /33 40	UW2440	1	D1540	1	BL1540
WBC33 /36 40	UW2440	1	D1840	1	BL1540
WBC36 /39 40	UW2440	1	D2140	1	BL1540

Blind panel on the left

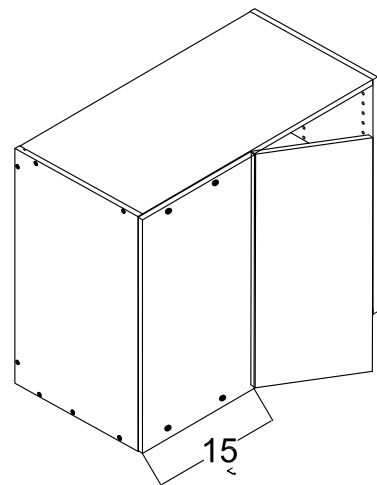
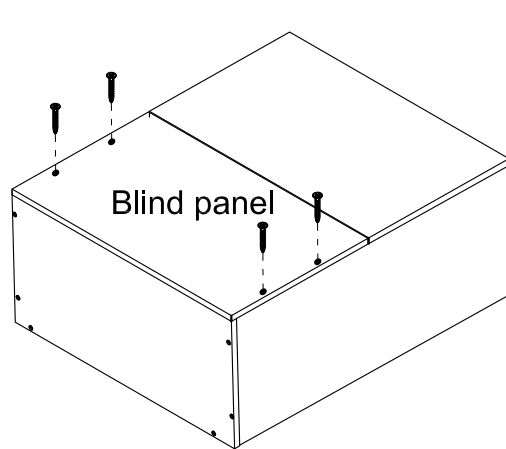
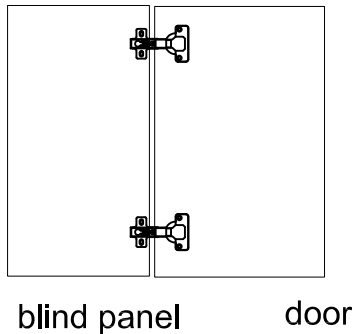

Blind panel on the right

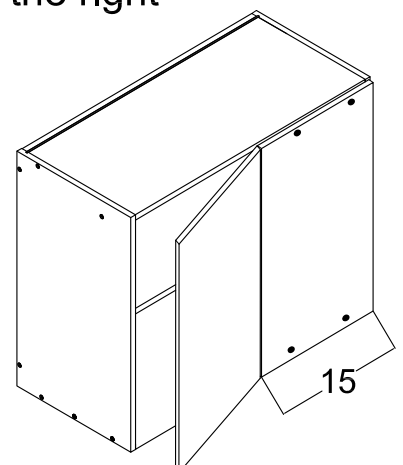
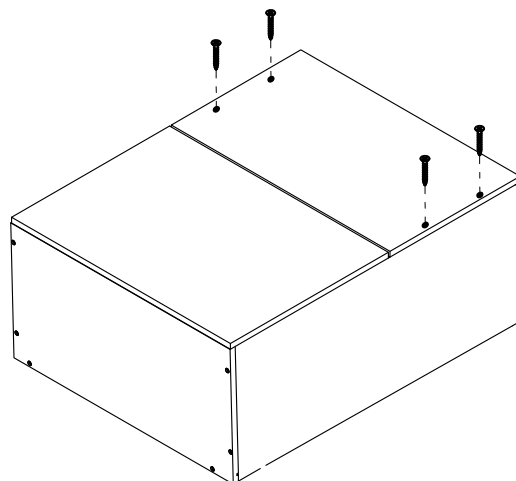
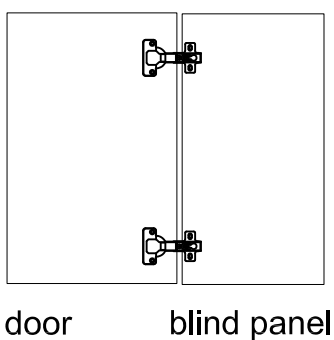

H=23" Optional legs purchase requirements to convert wall cabinet into 23"H Base Cabinet

ITEM NO.
UW122324
UW152324
UW182324
UW242324
UW302324
UW332324
UW362324

1. Full door-optional Legs purchase requirement

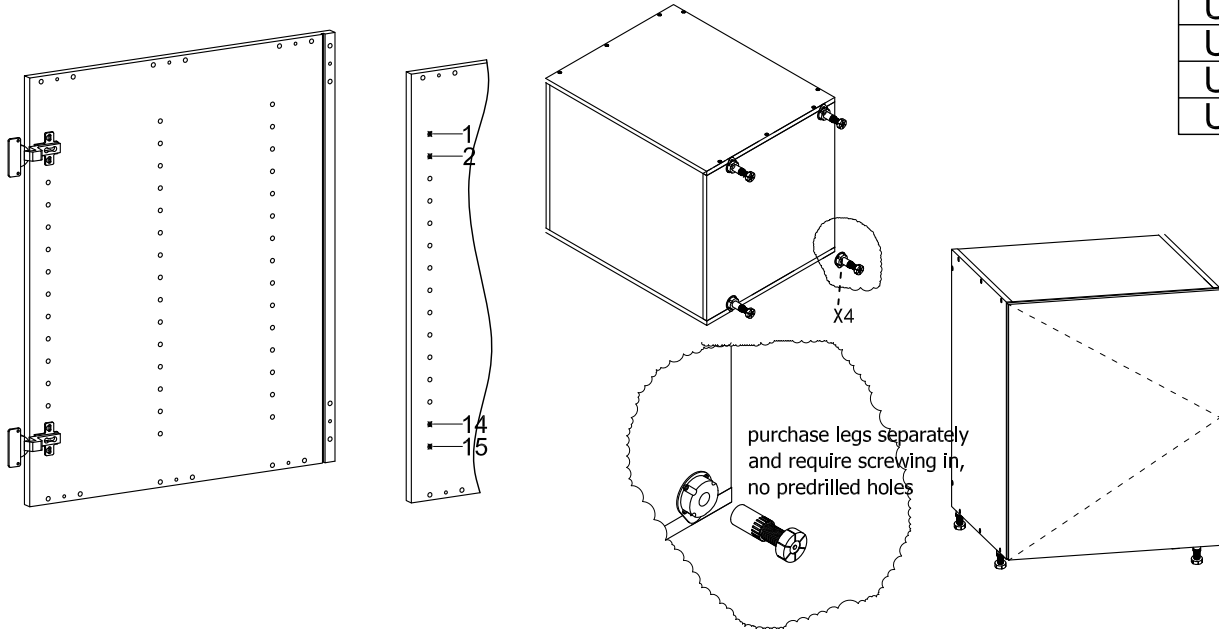

2. Two drawers

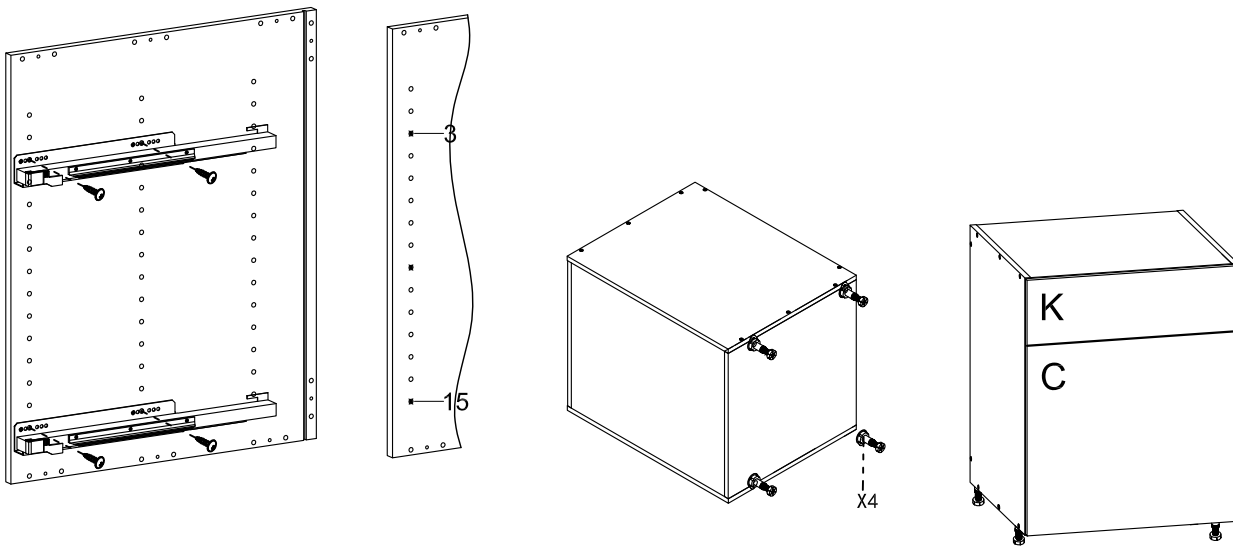

3. Three drawers

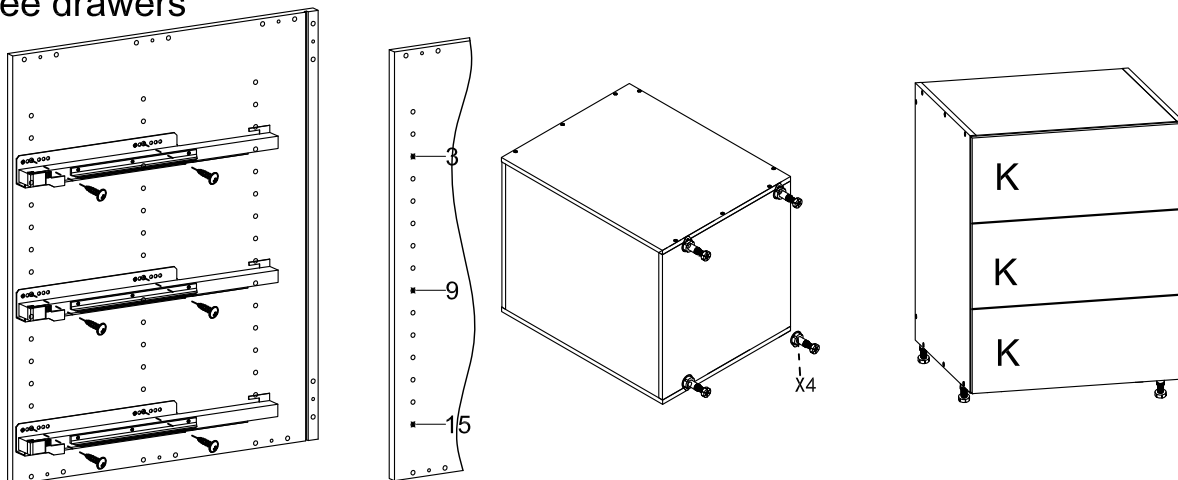

1 Assembly
First, slide all the hinges, from the front, onto the mounting plates.

2 Then press lightly on each successive hinge until the arm latches onto the mounting plate with an audible click!

3 Disassembly
It is carried out in the opposite direction from bottom to top. The hinge is unlatched by pressing lightly on latch (1) which is hidden under the side arm.

4 In one movement, the hinge arm is lifted off the mounting plate (2) and the door is removed from the cabinet (3).

i Remove cover cap for hinge adjustment

Adjustment

- 1. Overlay adjustment: + 2 / - 2 mm**
Turn screw (A) clockwise: Door overlay decreases (-).
Turn screw (A) anticlockwise: Door overlay increases (+).
- 2. Depth adjustment: + 3 / - 2 mm**
Direct, infinitely variable depth adjustment by turning the screw (B).
- 3. Height adjustment: + 2 / - 2 mm**
Loosen fixing screws (C) slightly and adjust height of door. Then tighten fixingscrews again.

Technische Änderungen vorbehalten.
Keine Gewährleistung für Druckfehler
und Irrtümer.

Subject to technical alterations.
Errors and omissions excepted.

Sous réserve de modifications techniques.
Notre responsabilité ne sera engagée
en cas de fautes de frappe ou d'erreurs.

Salvo modifiche tecniche.
Nessuna garanzia per errori di stampa
ed errori.

Se reserva el derecho a realizar modificaciones técnicas.
No ofrecemos garantía alguna respecto a eventuales
erratas de impresión u otros errores.

Technische wijzigingen voorbehouden.
Wij zijn niet verantwoordelijk voor
drukfouten of andere vergissingen.

DRAWER BOX HEIGHT



K

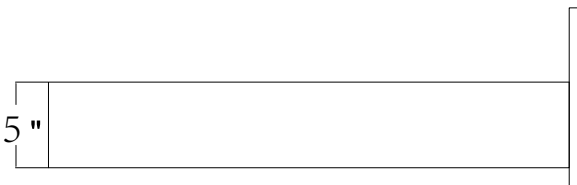

K

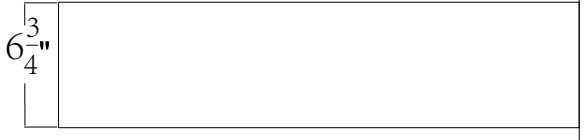

C

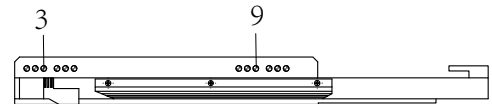

Drawer Box

Assembly and adjustments

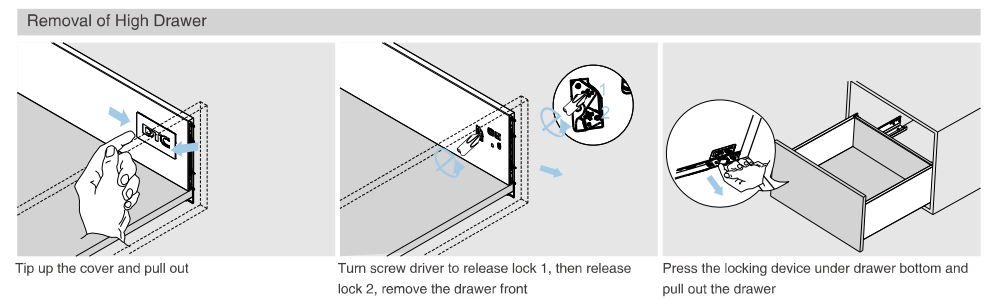
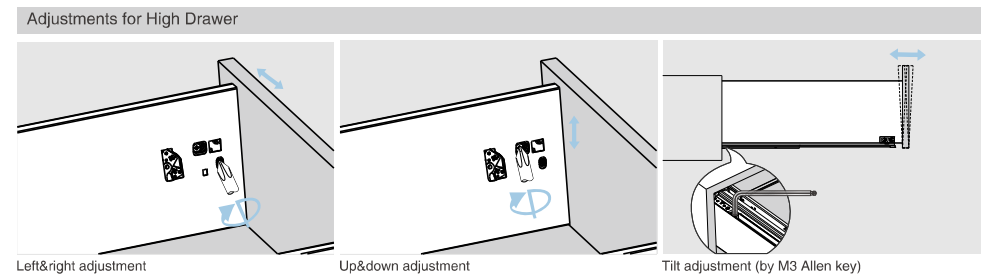
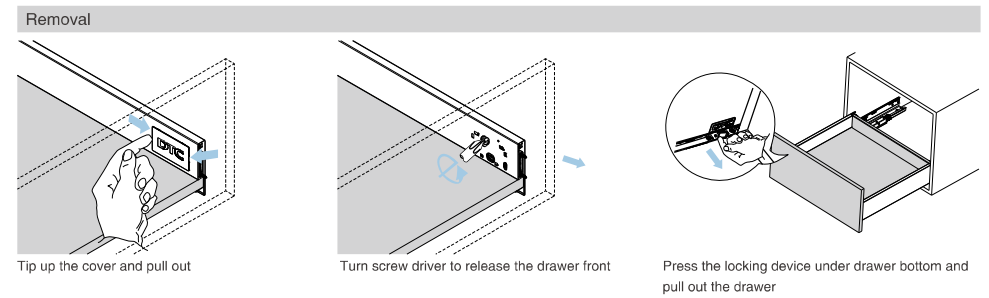
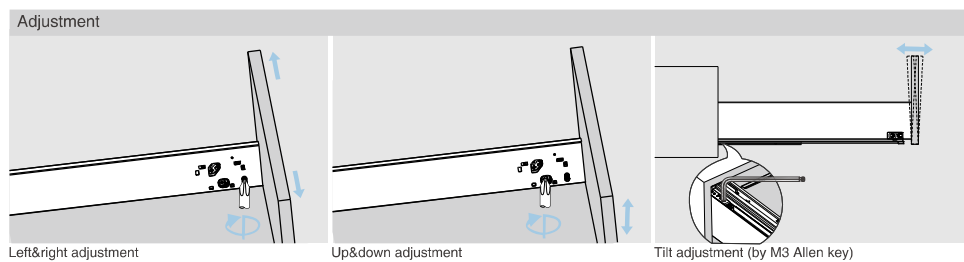
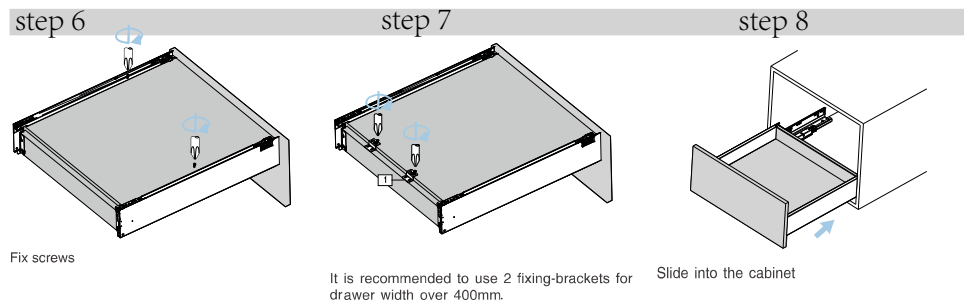
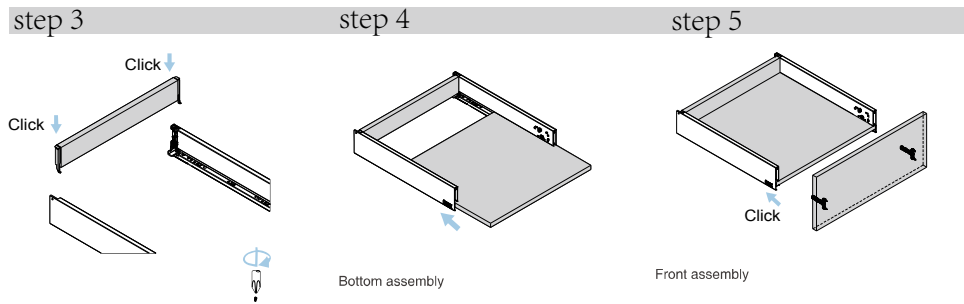
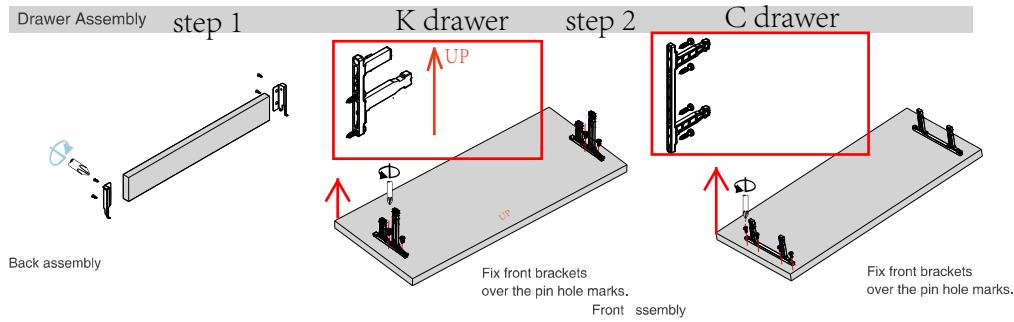

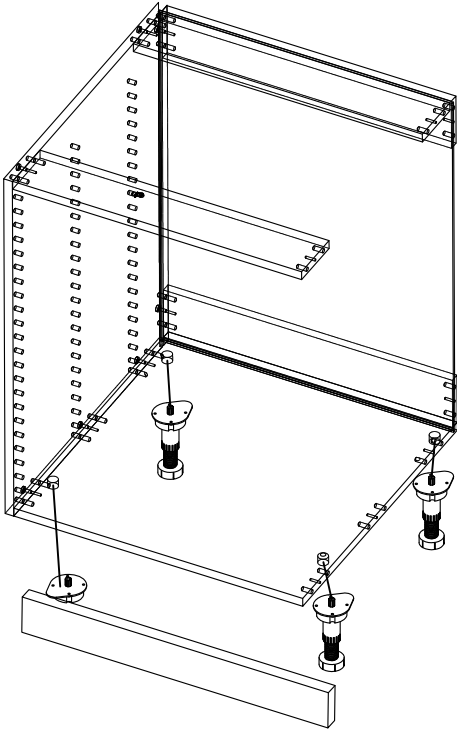

front

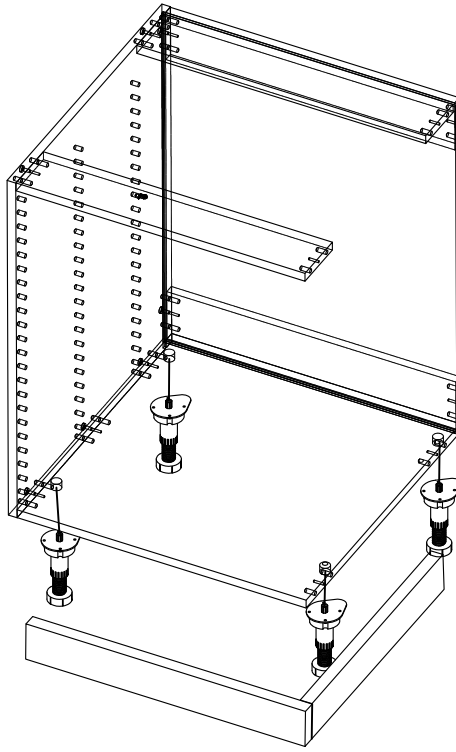

front and right

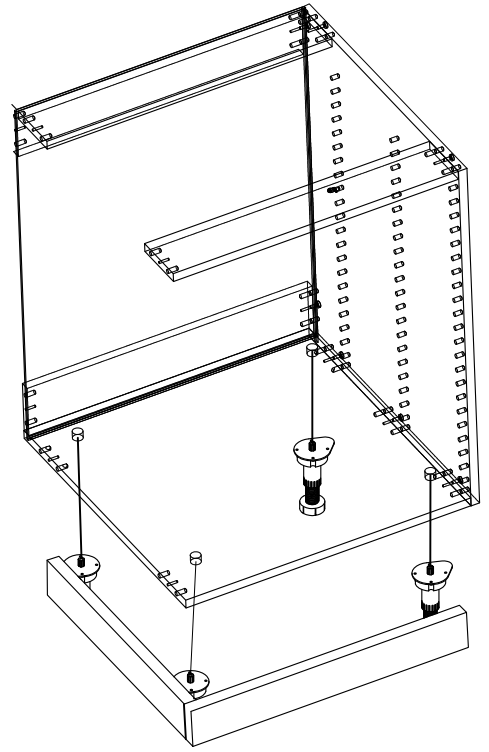

front and left

LEGS AND TOEKICK

require screwing in and
predrilled holes

